

# Determination of the Dielectric Stresses that Appear in the Windings of a Lightning Impulse Autotransformer

Maria Cristina Nițu, Marcel Nicola, Marian Duță and Mircea Alin Benea

National Institute for Research Development and Testing in Electrical Engineering-ICMET Craiova/  
Research, Development Division for Electric Equipment and Energy Efficiency, Craiova, Romania  
cristinamarianitu@yahoo.com, marcel\_nicola@yahoo.com, marianduta@icmet.ro, abenea@icmet.ro

**Abstract** -This paper presents two methods for determining the dielectric stresses occurring in the tap winding of a lightning pulse autotransformer. The first method is to implement the equivalent circuit using the ATP / EMTP program, and the second method consists in testing the autotransformer at a low voltage impulse before being put into the tank. The design of the autotransformer was done taking into account the results obtained with ATP/EMTP. This fact allowed the design of the winding structure as well as their location in space to obtain uniformly distributed overvoltages along the axial and radial direction of the coil assembly. The results of the laboratory tests performed on the autotransformer, validated the results obtained with ATP / EMTP.

**Cuvinte cheie:** bare capsulate, curenți intensi, model magnetic in regim armonic, model termic staționar, probleme cuplate.

**Keywords:** autotransformer; lightning impulse; transient regime.

## I. INTRODUCTION

The transformer is the most important equipment in the electric power transmission and distribution system. Its importance derives both from its high cost and from the fact that it ensures the proper operation of the national energy system.

Extreme dielectric and mechanical stress occurs in the case of transient regimes such as: overvoltage caused by lightning impulse, no-load connection and two or three-phase short-circuit.

Since surges can cause major malfunction in transformers, it is of great interest to improve the models for computer-assisted simulation of transformer phenomena aiming at a correct prediction to eliminate the negative consequences.

The optimization of the design leads to the reduction of the manufacturing costs by using the minimum quantity of oil, paper, cardboard, stainless steel, copper wire and electromagnetic board, but also the decrease of the failure rate during the technical performance validation tests. The use of advanced modeling techniques for the electric and magnetic circuits implemented in high-performance numerical resolution programs provides research tools both for designing the structure of the windings and for locating them in order to achieve evenly distributed overvoltage.

Various methods and approximations have been presented in the specialized literature to determine the dielectric stress which occurs when the transformer/autotransformer undergoes lightning impulse testing.

As the analytical approach to the determination of the response of the windings to the lightning impulse stress became complicated with the transition from uniform windings to interleaved windings, this problem was transferred to numerical methods for solving differential equations that define electromagnetic phenomena in the transformer. At the same time it was passed from the theories of the standing waves, respectively, travelling waves applied to determine the response of transformer windings at surge stress to the simulation of the winding with circuits with lumped parameters. The analysis of such a network divided into a finite number of uniform sections, by using the Laplace transform was presented in [1].

The application of the Runge-Kutta method to solve the 2nd order differential equations for the purpose of determining the distribution of the voltage impulse along the winding of a transformer was given in [2].

In [3] is approached the equivalent network of a three-phase transformer which is characterized by a 2nd order equation with matrix coefficients. This equation is solved by the Milne method [4]. The same type of equation is solved in [5] and [6] by converting it into a system of two ordinal 1 equations, which in turn were solved by recursive integrations.

The MATLAB Program currently has a standard function, built to solve the 1st order systems [7]. If the equivalent circuit of the windings also contains mutual inductances, they are replaced by uncoupled elements by using the analytical relations presented in [8]. In this way the circuit can be analyzed by using the methods described above, because it is a purely resistive circuit.

The difficulty of achieving the equivalent circuit is given by the existence during the transient regime, of both the electric field and the variable magnetic one over time.

The two fields influence the value of capacitances, of the self-inductance and mutual inductance and of the resistance. In order to reduce the difficulty of solving partial differential equations, the analyzed winding is described by sections where the inductances and capacitances are represented by lumped parameters, and partial differential equations are approximated by ordinary differential equations that are resolved by numerical analysis.

One of the most accurate descriptions of the equivalent circuit is the description of the winding by the capacitance between the turns, resistances and the associated inductances [9].

Another proposed model [10], [11] consists in the representation of the transformer by two electromagnetic coupling circuits. In this model, the variable magnetic flux over time induces in the electrical circuit a voltage that establishes a level of the electrical current, which by the resulting current linkage constitutes in the magnetic circuit a source which, depending on the magnetic reluctances, establishes a new level of magnetic flux.

The models based on the inductance and self-capacitance of an area in the winding interfaced with a magnetic core model by using the duality principle are described in [12], [13], [14].

Based on the principle of electric and magnetic coupling circuits Dommel achieved the first variant of the ATP/EMTP program [15].

ATP/EMTP (Alternative Transient Program – Electromagnetic Transient Program) is used worldwide for the analysis of the switching phenomena and the propagation of lightning wave on the lines of transmission or distribution of electricity, the coordination of the network insulation and the study of voltage oscillations, the modeling of relay protection, the study of harmonics and the quality of electricity [16-19].

The ATP/EMTP program package is a very powerful software means for analysis of transient regimes in electrical networks of high voltages, which gives the user the possibility of modeling the polyphase networks of the extended networks [20], [21] as well as the investigation of faults in the electrical network [22], are associated with a high computing speed.

II. THEORETICAL CONCEPTS

Test circuit with lightning impulse of the autotransformer is shown in Fig. 1, and the layout of the tap coil relative to the tertiary (T), secondary (JT) and primary coils (IT) in Fig. 5.

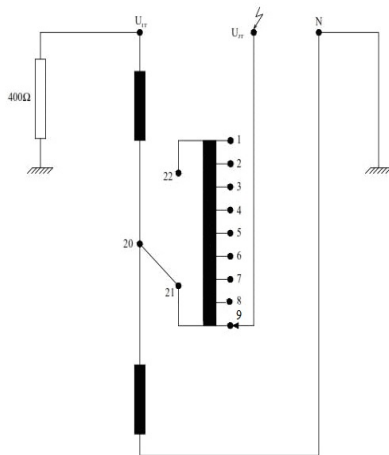

Fig. 1. Test circuit with lightning impulse.

The tap winding is executed from the CTC (Continuously Transposed Conductor) (see Fig. 2) conductor and the type of winding is continuous in two layers (see Fig. 3).



Fig. 2. Conductor CTC (Continuously Transposed Conductor).

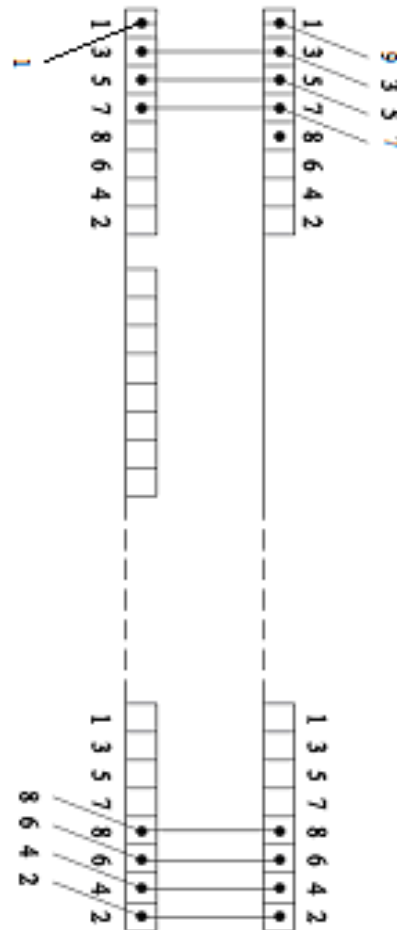

Fig. 3. Placing in two layers of tap coil turns.

The CTC is used the most for the windings of power autotransformers/transformers. It consists of a set of enamel rectangular conductors, usually with PVF enamel, which are twisted to create a rectangular cable. In this set each wire takes successively and repeatedly every position possible within the cross section of the conductor.

The bulk wires are wrapped in pure cellulose paper strips. This conductor is used to manufacture low-loss windings for high-power autotransformers/transformers.

The increase of power of autotransformers/transformers has intensified the need for increased efficiency.

According to the “Ecodesign” European Directive it is necessary to drastically reduce the losses that occur at the operation of an autotransformer/transformer and the use of the CTC windings has improved this important feature of the construction of autotransformers/transformers.

The adoption of the CTC presents a great advantage by reducing the losses through eddy currents, especially at the end of the windings.

In addition, a considerable increase in the winding space factor is possible, due to the very small thickness of the insulation of separate conductors and it is possible to obtain a more uniform distribution of the temperature from one end to the other of the winding.

An electrical circuit consists of two CTC conductors in parallel (see Fig. 4)

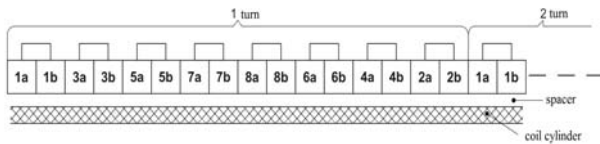

Fig. 4. Explicit transposition inside CTC conductors.

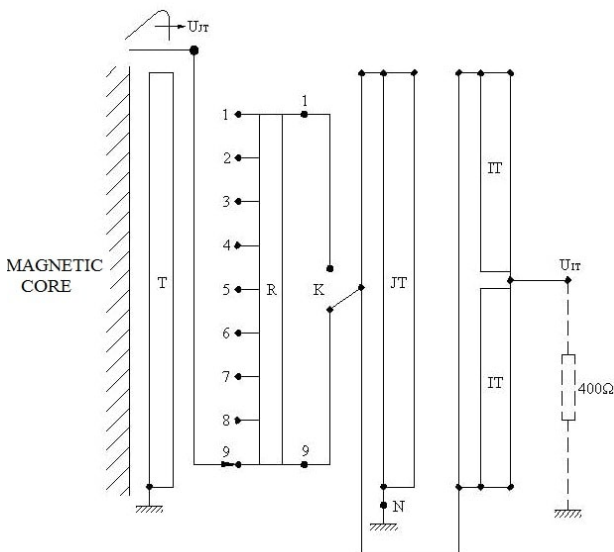

Fig. 5. Tap coil layout.

#### A. Calculation of self-inductances

The inductance of the layer placed on the insulating cylinder of the coil [7]:

$$4L_1 = \mu_0 \cdot N^2 \cdot \frac{\pi \cdot a_1}{l} \quad (1)$$

where:  $L_1$  - is the inductance of one of the four sections forming the first layer,  $\mu_0$   $H/m$  - magnetic permittivity,

$N$  - number of turns of the first layer,  $a_1$  - mean radius of the coil,  $l$  - the length of the coil between two consecutive steps of the tap coil.

The inductance of the second layer is different from that of the one layer medium radius of the winding having another value ( $a_2$ ) [7]:

$$4L_2 = \mu_0 \cdot N^2 \cdot \frac{\pi \cdot a_2}{l} \quad (2)$$

#### B. Calculation of capacitances to ground

Capacitance between the tap coil and the tertiary coil (neglecting solid insulation):

$$C_{R-T} = \frac{2 \cdot \pi \cdot \epsilon_0 \cdot \epsilon_{ru} \cdot l}{\ln \frac{R_{ir}}{R_{et}}} \quad (3)$$

$\epsilon_0$  - electric permittivity of vacuum,  $\epsilon_{ru}$  - electric permittivity of oil,  $l$  - length of tap coil,  $R_{ir}$  - inner radius of tap coil,  $R_{et}$  - outer radius of tertiary coil.

#### C. Capacitance between tap coil and secondary coil (LV)

$R_{jT}$  - represent the inner radius of secondary coil and  $R_{er}$  - outer radius of tap coil

$$C_{R-JT} = \frac{2 \cdot \pi \cdot \epsilon_0 \cdot \epsilon_{ru} \cdot l}{\ln \frac{R_{jT}}{R_{er}}} \quad (4)$$

#### D. Calculation of capacitances between the two layers of the tap coil at the free end area

$$C_{1-9} = \frac{2 \cdot \pi \cdot \epsilon_0 \cdot \epsilon_{ru} \cdot l_r}{\ln \frac{R_{is2}}{R_{es1}}} \quad (5)$$

$l_r$  - length of the segment in the coil of the tap winding containing its potential-free end;

$R_{is2}$  - the inner radius of the layer 2;

$R_{es1}$  - outer radius of the layer 1.

Due to the fact that the first layer has 8 segments, each of 8 turns,  $l_r = \frac{l}{8}$  :

#### E. Calculation of series capacitance of tap winding

If the tap winding has 8 electric circuits with 8 turns in the circuit, we approximate that the voltage is evenly distributed along the 64 turns.

If the voltage applied at the end of the winding is noted “U”, it results that the voltage on the turn is “U/64”.

Considering that when switching from a position of the load control switch, the next position creates surges up to 20 times higher than the voltage on a coil, increasing the insulation, for example: twice the insulation between the

neighboring spirals exit to the switch at each stage of adjustment.

Thicker paper insulation means reduced capacitance between turns, which is offset by increased capacitance through end effect. The energy stored in the tap winding has the following expression [7]:

$$E_R = 8 \cdot \left\{ 6 \left[ \frac{1}{2} \cdot C \cdot \left( 8 \cdot \frac{2U}{64} \right)^2 \right] + \frac{1}{2} \cdot C \cdot \left( 8 \cdot \frac{U}{64} \right)^2 \right\} + 7 \cdot \left[ 7 \cdot C \cdot \left( 7 \cdot \frac{U}{64} \right)^2 \right] \quad (6)$$

where:  $C$  represent the capacitance between two turns.

In the equation (6), by twice increasing the thickness of the insulation to 6 pairs of coils adjacent to the output of an adjustment step, for the energy conservation doubled the voltage on the coil.

Usually the insulation is increased for the next 3 adjustment steps, in both directions, adjacent to the adjustment voltage corresponding to the rated voltage.

$$E_R = 8 \cdot \left[ 6 \cdot \frac{1}{2} \cdot C \cdot \left( \frac{16U}{64} \right)^2 + \frac{1}{2} \cdot C \cdot \left( \frac{8 \cdot U}{64} \right)^2 \right] + \frac{7}{2} \cdot C \cdot \left( \frac{7 \cdot U}{64} \right)^2 = \frac{48}{2} \cdot C \cdot \frac{16^2 \cdot U^2}{64^2} + \frac{8}{2} \cdot C \cdot \frac{8^2 \cdot U^2}{64^2} + \frac{7}{2} \cdot C \cdot \frac{7^2 \cdot U^2}{64^2} = 1.6 \cdot C \cdot U^2 \quad (7)$$

If we note with  $C_{s1}$  the total series capacitance of a step in the tap winding, it results from the equality between the stored energy that:

$$\frac{3.2 \cdot C \cdot U^2}{2} = \frac{C_{s1} \cdot U^2}{2} \quad (8)$$

so  $C_{s1} = 3.2 \cdot C$

The capacitance between two turns is calculated by the relation:

$$C = \frac{\varepsilon_0 \cdot \varepsilon_h \cdot \pi \cdot D_m (h_c + k)}{t_h} \quad (9)$$

where:

- $\varepsilon_0$  - is the permittivity of vacuum,
- $\varepsilon_h$ - relative permittivity of the oil-impregnated paper,
- $D_m$ -average diameter of the tap winding,
- $h_c$ - height of conductor in radial direction,
- $k$ - end effect coefficient ( $k=0,025$ ),
- $t_h$  - thickness of paper insulation.

The total capacitance between turns is:

$$C_{total} = 4 \cdot C \quad (10)$$

The total series capacitance of a control step of the winding has the value

$$C_s = 3.2 \cdot C_{total} \quad (11)$$

#### F. Calculation of tap winding resistance

With  $R_{cc}$  we note the measured DC resistance of a tap step. For the equivalent circuit of the tap winding, the resistance will be calculated taking into account the penetration of the electric field with the electrical frequency of 15 kHz to the conductor winding.

The frequency of 15 kHz is specific to the lightning impulse wave front [10]. Corresponding to this frequency, the penetration depth is 0.6 mm, according to the relation [7]:

$$\delta = \frac{1}{\sqrt{\pi \cdot f \cdot \mu \cdot \sigma}} \quad (12)$$

It results that the equivalent resistance for a tap step is:

$$R = R_{cc} \frac{S_{cu}}{S^*} \quad (13)$$

where:

$S_{Cu}$  - the conductor section,

$$S^* = 2 \cdot \pi \cdot r \cdot \delta \quad (14)$$

$S^*$  -the equivalent section for high frequency

$r$  - the copper conductor radius,

$\delta$  - the depth of penetration of the electric field in the copper section.

Input capacitance value can not be increased enough to provide insulation between inlet and coil layers. For this reason, it is necessary to determine by numerical modeling the voltage level that occurs at the endless potential end of the control winding. This optimizes the level of insulation required in the tap winding area.

### III. SIMULATION RESULTS

This choice was made taking into consideration the statistical results of the defects occurred after the laboratory testing with high voltage lightning impulse (for voltage rating 400kV the impulse voltage level is of 1425kV, and for voltage rating of 231kV the impulse voltage level is of 1050kV, according to standards [23], [24].

The surge that occurs at the potential-free end of the tap winding is due to its free oscillation.

The model of tap winding energized directly by the lightning impulse (see Fig. 1) is an R-L-C network with lumped parameters invariable in time (Fig. 6).

For the validation of the proposed model was performed this test with low voltage lightning impulse.

The circuit proposed to be implemented in the ATP/EMTP program, is for a three-phase oil immersed autotransformer ATUS-OFAF 400/400/80MVA; 400/231±8x1.25%/22kV (see Fig. 6). The program has a library of comprehensive electrical symbols and an interactive interface that allows the achievement of the wiring diagram and the analysis of the operating conditions without delay.

The results obtained with the ATP/EMTP program for three-phase autotransformer ATUS-OFAF 400/400/80 MVA; 400/231±8x1.25%/22 kV are presented in figures 7, 8, 9.

According to the literature [1], [2], [6] and [7] in order to obtain a uniform distribution of the lightning impulse voltage, the size of the input capacitance must be as large as possible, and the ratio between the magnitude of the series capacitance of the adjustment infiltration and the size of its capacitance towards the ground is approaching the unit.

The input capacitance value cannot be increased enough for reasons of insulation insurance between the input turns and between the layers. For this reason a compromise is made between the level of insulation of the end free of potential of the tap winding. These insulation levels are influenced by the level of insulation between the turns of the winding. To optimize these levels it is necessary to use the specialized ATP/EMTP program.

In Fig. 6 it is presented the circuit proposed to be implemented in the ATP/EMTP program where  $C_{R-JT}/3$  and  $C_{R-T}/3$  - represent the dynamic capacitances between the tap winding and the secondary winding with earthed neutral, respectively between the tertiary winding and ground.

In the first analyzed case the capacitance  $C_{1-9}$  has the value, and the waveform obtained is shown in Fig. 6.

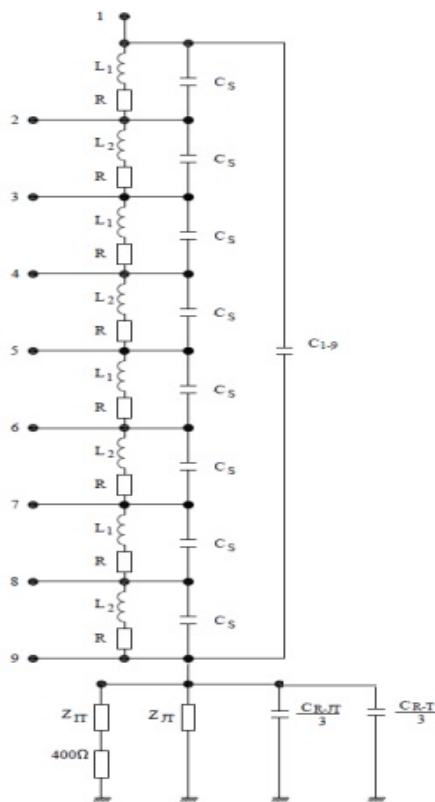

Fig. 6. The circuit proposed to be implemented in the ATP/EMTP program.

In order to highlight the importance of choosing the type of interweaving and the reciprocal lay-out of the two winding steps, two other cases were simulated where the capacitance had the values:0.34 nF and 9.78 nF.

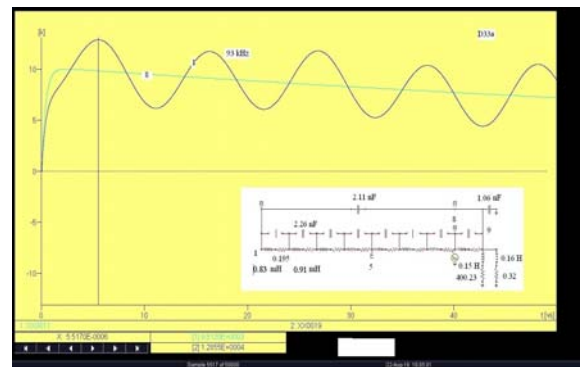

Fig. 7. The waveform of the surge transmitted at the free end of the tap winding of an autotransformer (ATP/EMTP).

$$U_{\max \text{ trans}} = 1.28 \cdot U_{\max \text{ imp}}, t_{U_{\max}} = 5.5 \mu\text{s}, f = 93 \text{ kHz}$$

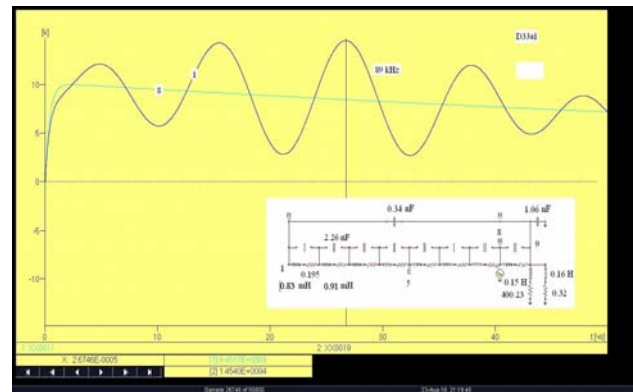

Fig. 8. The waveform of the surge transmitted at the free end of the tap winding of an autotransformer when the capacitance is 0.34nF (ATP/EMTP).

$$U_{\max \text{ trans}} = 1.45 \cdot U_{\max \text{ imp}}, t_{U_{\max}} = 23 \mu\text{s}, f = 111 \text{ kHz}$$

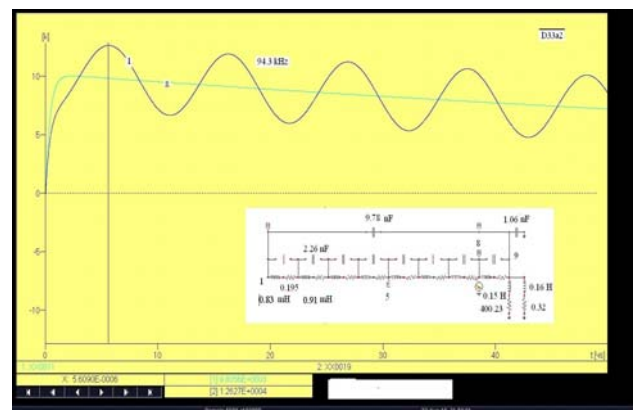

Fig. 9. The waveform of the surge transmitted at the free end of the tap winding of an autotransformer the capacitance is 9.78 nF (ATP/EMTP).

$$U_{\max \text{ trans}} = 1.26 \cdot U_{\max \text{ imp}}, t_{U_{\max}} = 5.5 \mu\text{s}, f = 94.3 \text{ kHz}$$

#### IV. EXPERIMENTAL RESULTS

The structure of the circuit for experimental determination of surges that propagate at the free end of the tap winding of an autotransformer subjected to low voltage lightning impulse is presented in Fig. 10.

Measuring equipment and apparatus contained in the measuring circuit for voltages transmitted are: Repeated impulse generator (GIR), 100W/220V, 50Hz HAEFELY-Switzerland; Oscilloscope type AGILENT 54624A, USA; Pentium 4 computer.

For an autotransformer, single low-voltage impulses were applied to position 8 of the tap winding a lightning impulse type voltage with the maximum amplitude of 120 V and the time parameters 1.2/100  $\mu$ s and was recorded the surge transmitted at position 1, which represents the free end of the tap winding.

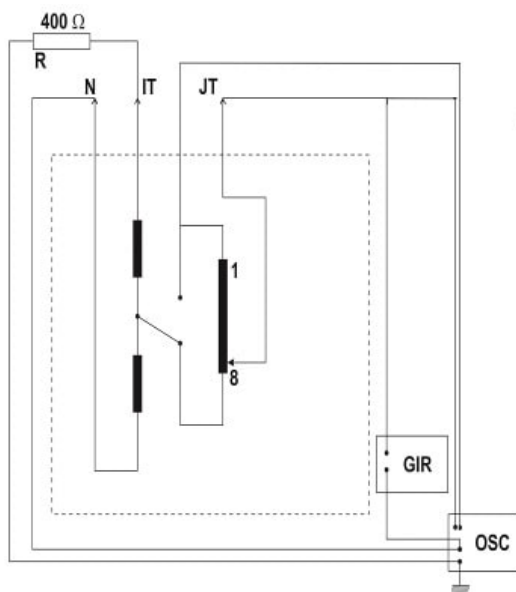

Fig. 10. The circuit for experimental determination of surges that propagate at the free end of the tap winding of an autotransformer subjected to low voltage lightning impulse.

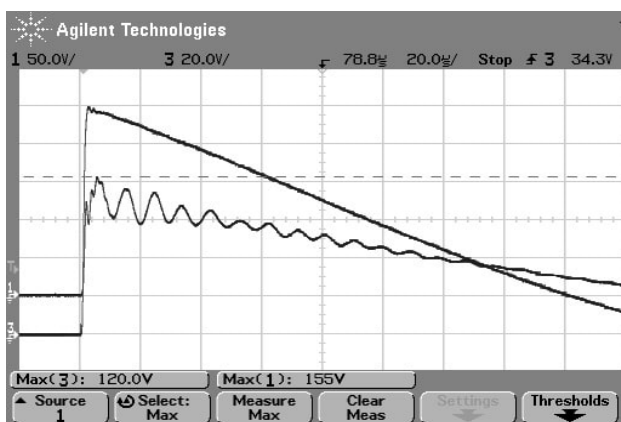

Fig. 11. The recorded waveform of the voltage transmitted at the free end of the tap winding of a 400MVA/400kV autotransformer when it was subjected to lightning impulse.

$$U_{\max \text{ trans}} = 1.28 \cdot U_{\max \text{ imp}}, t_{U_{\max}} = 5.5 \mu\text{s}, f = 100 \text{ kHz}.$$

The oscilloscope was programmed to display the maximum values of the two phenomena recorded as well as the time bases (common for both phenomena) and amplitude (two scales 20V/div and 50V/div respectively).

The results obtained in the test laboratory for a three-phase autotransformer 400 MVA/400kV are presented in Fig. 11.

Compared to the results obtained from the simulation, (see Fig. 7, 8, 9) the differences are very small.

#### V. CONCLUSIONS

For the validation of the electric circuit with the concentrated parameters implemented in the ATP / EMTP program, as well as the formulas for calculating the concentrated parameters from the electrical circuit, the solution of comparing the simulation result with the result of the direct measurement of the overvoltage transmitted to the free end of a real adjustment winding was chosen (from the construction of an autotransformer with the power of 400 MVA and the nominal voltage 400 kV) by injecting a pulse with the time parameters 1.2 / 100  $\mu$ s and the maximum amplitude 120 V.

There are very small differences between the results obtained by applying the two methods presented in this paper, the percentage error between the value of the voltage obtained by simulation and the one resulting from the measurement is 0.3%.

The analysis of the results shows that it is important for the value of the tap winding input capacitance to be greater than the dynamic capacitance between tap winding and ground. The value of the input capacitance cannot be increased sufficiently due to the insulation between the winding input turns and between layers. For this reason, a compromise is made between the level of insulation of the free end of the tap winding potential and the level of insulation at the input of the tap winding. These levels of insulation are determined by the level of insulation between the turns of the windings.

At the first analysis it can be concluded that the use of this type of winding is perfect, but taking into consideration the difficulty of the execution of this type of winding and the duration necessary to achieve it arises the problem of reduced productivity. By numerical modeling of the transient phenomena manifested in the windings, new solutions can be implemented, such as the winding interleaved in steps at which the element subjected to optimization is the length of the winding section interleaved and the rest achieved with continuous winding and also how the connection is made with the partially interleaved tap winding.

In the case study presented it was analyzed the importance of sizing the axial insulation at the ends of the tap winding and the importance of the connections between the wires in the structure of the transposed conductor (CTC).

The modification of the longitudinal and radial insulation between the layers of the coil led to obtaining different values of the surges transmitted at the free end of the tap winding. To obtain a value of the voltage distribution

constant  $\alpha = \sqrt{\frac{C_m}{C_s}}$ , as close as possible to the value

"1", it was imagined an original system for potential reali-

zation of the conductive elements in the structure of the CTC conductor.

The design of the autotransformer was done taking into account the results obtained with ATP / EMTP. This fact allowed the design of the winding structure as well as their location in space to obtain uniformly distributed overvoltages along the axial and radial direction of the coil assembly. The results of the laboratory tests performed on the autotransformer, validated the results obtained with ATP / EMTP.

#### ACKNOWLEDGMENT

The paper was developed with funds from the Ministry of Research and Innovation as part of the NUCLEU Program: PN 16 15 01 09 and PN 19 38 01 03.

Contribution of authors:

First author – 50%

First coauthor – 30%

Second coauthor – 10%

Third coauthor – 10%

Received on October 2, 2019

Editorial Approval on November 25, 2019

#### REFERENCES

- [1] T. J. Lewis, "The transient behaviour of ladder networks of the type representing transformer and machine windings," in Proceedings of the IEE - Part II: Power Engineering, vol. 101, no. 83, pp. 541-553, October 1954.
- [2] K. A. Okunuyama, "A numerical analysis of impulse voltage distribution in transformer windings," in Electrical Engineering in Japan, vol. 87, pp. 80-88, 1967.
- [3] A. Miki, T. Hasoya, and K. Okunuyama, "A Calculation Method for Impulse Voltage Distribution and Transferred Voltage in Transformer Windings," in IEEE Transactions on Power Apparatus and Systems, vol. PAS-97, no. 3, pp. 930-939, May 1978.
- [4] K. S. Kunz, *Numerical Analysis*, McGraw-Hill Book Company Inc., 1957.
- [5] P. I. Fegerstad and T. Henriksen, "Transient Oscillations in Multiwinding Transformer," in IEEE Transactions on Power Apparatus and Systems, vol. PAS-93, no. 2, pp. 500-509, March 1974.
- [6] R. Kasturi and G. R. K. Murty, "Computation of impulse-voltage stresses in transformer windings," in Proceedings of the Institution of Electrical Engineers, vol. 126, no. 5, pp. 397-400, May 1979.
- [7] S. V. Kulkarni and S. A. Khaparde, *Transformer Engineering: Design and Practice*, Marcel Dekker, 2004.
- [8] H. J. Carlin and A. B. Giordano, *Network Theory*, Prentice-Hall Inc., 1964.
- [9] M. C. Nițu, M. Nicola, M. Duță, and M. A. Benea, "Methods for determining dielectric stresses in the windings of a transformer subjected to lightning impulse," *12<sup>th</sup> International Conference and Exhibition on Electromechanical and Energy Systems - SIELMEN*, Chisinau, Moldova, 2019, pp.1-6
- [10] F. De Leon, A. Semlyen, "Complete transformer model for electromagnetic transients," in IEEE Transactions on Power Delivery, vol. 9, no. 1, pp. 231-239, Jan. 1994.
- [11] A. Tugulea, C. Fluerașu, D. Daniel, and D. Popa, "Physical and Mathematical Modelling of Transients within the Transformer Windings," Proceeding I. C. P. Electroputere Craiova, 1978.
- [12] M. C. Nițu and M. Duță, "Calculation of Surges Transmitted Between Transformer Windings Using the Coupled Circuit Model," *International Conference on Applied and Theoretical Electricity (ICATE)*, Craiova, 2018, pp. 1-6.
- [13] H. W. Dommel, "Transformer Models in the Simulation of Electromagnetic Transients," *5<sup>th</sup> Power Systems Computation Conference*, 1975, pp. 1-4.
- [14] E. Colin Cherry, "The Duality between Interlinked Electric and Magnetic Circuits and the Formation of Transformer Equivalent Circuits," in Proceedings of the Physical Society. Section B, vol. 62, no. 2, pp. 101-111, February 1949.
- [15] F. De Leon and A. Semlyen, "Reduced order model for transformer transients," in IEEE Transactions on Power Delivery, vol. 7, no. 1, pp. 361 - 369, January 1992.
- [16] H. W. Dommel and S. Bhattacharya, V. Brandwajn, H. K. Lauw and L. Marti, *Electromagnetic Transients Program Reference Manual. (EMTP Theory Book) - 2nd Edition*, Bonneville Power Administration, Portland, USA, 1992.
- [17] J. C. Escamilla Sánchez, C. Tejada Martínez, and P. Gómez Zamorano, "Single-phase transformer modeling for analyzing transient overvoltages distribution and transference," in IEEE Latin America Transactions, vol. 7, no. 5, pp. 545-551, September 2009.
- [18] G. Cividjan, Gh. Călin, D. Popa, and A. Dolan, "Modeling Lightning Surges in Power Transformers," *International Symposium on High Voltage and High Power Tests, Measurements and Qualification of Electric Power Equipment (SIMC - EE)*, 2004, pp. 1-6.
- [19] M. Istrate, M. Gușă, and C. Bucă, "ATP simulation analysis of the level of switching voltages in an electricity transmission network," *International Conference Energy of Moldova Chisinau*, Chisinau, Moldova, 2005, pp. 1-6.
- [20] Y. Zhou, C. Yang, W. Sima, L. Cai, X. Li, T. Yuan, and Y. Liu, "A Model Considering Deep Saturation of the Iron Core for 10 kV Potential Transformers," *IEEE International Conference on High Voltage Engineering and Application (ICHVE)*, Athens, Greece, 2018, pp. 1-4.
- [21] Shampa De, Abhinandan De, "Low cost surge voltage linearization methods for small rating power transformers," *IEEE Calcutta Conference (CALCON)*, Kolkata, India, 2017, pp. 69-73.
- [22] Mujtaba Ali, M. Asghar Saqib, "Transient analysis of a distribution transformer using ATP-EMTP," *International Conference on Power, Energy and Smart Grid (ICPESG)*, Mirpur Azad Kashmir, Pakistan, 2018, pp.1-6.
- [23] Zulkurnain Abdul Malek, S.J. Mirazimi, Kamyar Mehranzamir, Behnam Salimi, "Effect of shunt capacitance on ferroresonance model for distribution Voltage Transformer," *IEEE Symposium on Industrial Electronics and Applications*, Bandung, Indonesia, 2012, pp.124-129.
- [24] \*\*\*IEC 60076-1:2011-Power Transformer. Part. 1-General.
- [25] \*\*\*IEC 60076-3:2013-Power Transformer. Part. 3-Insulation levels, dielectric tests and external clearances in air.